

# Demco

## Truss-T Boom

21', 28', 30' and 40'

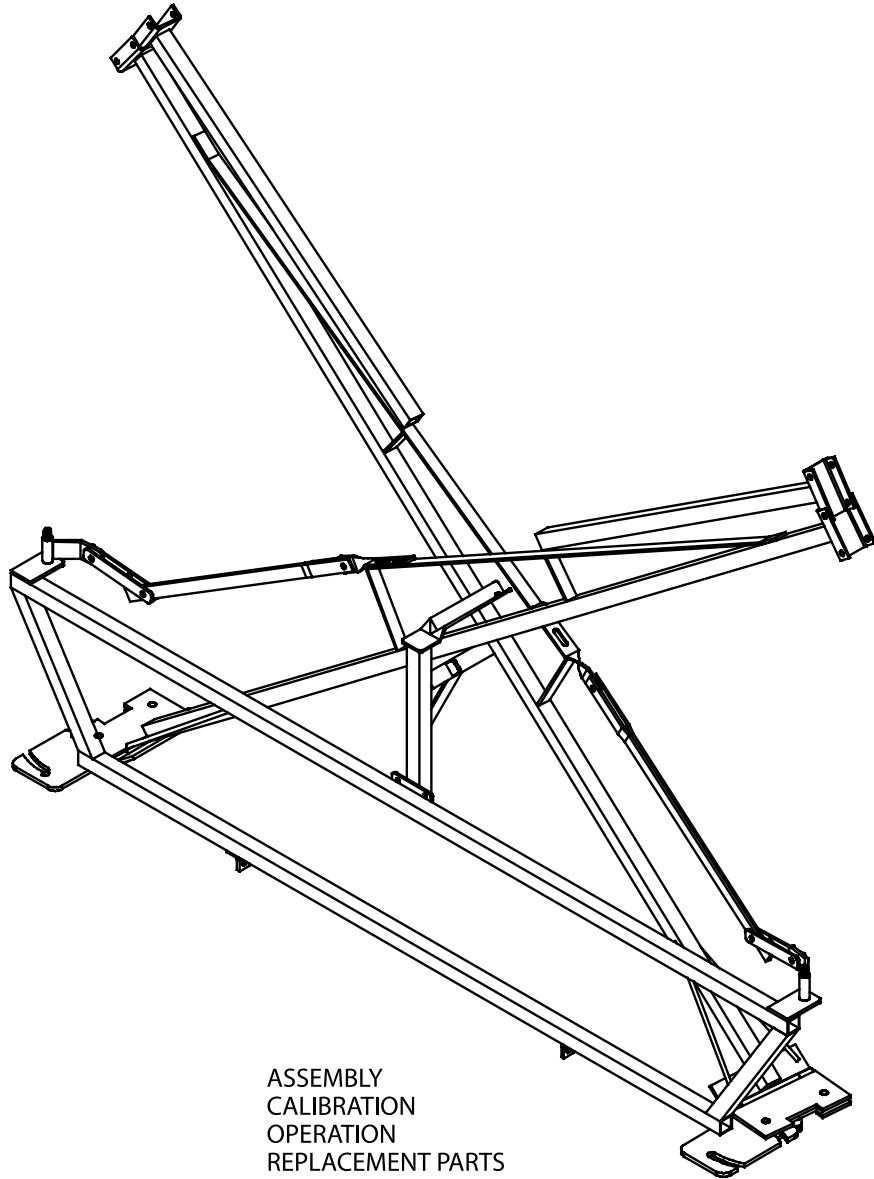

ASSEMBLY  
CALIBRATION  
OPERATION  
REPLACEMENT PARTS

**READ** *complete manual CAREFULLY  
BEFORE attempting operation.*

*Doing Our Best To Provide You The Best*

OPERATORS MANUAL

Thank you for purchasing a Demco spray boom. We feel you have made a wise choice and hope you are completely satisfied with your new boom. If you have any questions regarding the applications of certain solutions or chemicals, contact your chemical supplier and follow chemical manufacturer recommendations as well as all licensing and use restrictions or regulations.



**WARNING:** TO AVOID PERSONAL INJURY OR PROPERTY DAMAGE, OBSERVE FOLLOWING INSTRUCTIONS:

**Chemicals are dangerous. Know exactly what you're going to do and what is going to happen before attempting to work with these products. Improper selection or use can injure people, animals, plants and soil.**

**Always wear protective clothing such as coveralls, goggles and gloves when working with chemicals or sprayer.**

**Be sure to dispose of all unused chemicals or solutions in a proper and ecologically sound manner.**

## GENERAL INFORMATION

1. Unless otherwise specified, high-strength (grade5) (3 radial-line head markings) hex head bolts are used throughout assembly of this sprayer.
2. Whenever terms “**LEFT**” and “**RIGHT**” are used in this manual it means from a position behind sprayer and facing forward.
3. When placing a parts order, refer to this manual for proper part numbers and place order by **PART NO., DESCRIPTION, and COLOR.**

## Table of Contents

General information.....	2
Safety , Signal Words.....	3
Equipment Safety Guidelines.....	4
Lighting and Marking.....	4
Safety Sign Care .....	5
Tire Safety.....	5
Remember .....	5
Before Operation.....	6
During Operation.....	6-7
Following Operation .....	7
Highway and Transport Operations .....	8-9
Performing Maintenance .....	9
Bolt Torque .....	10
Spray Tip Assembly and Installation .....	11
Sprayer Calibration Procedures .....	12
Spray Tip Charts .....	13
Nozzle Parts Breakdown and List .....	14
21' - 30' Truss-T Boom Parts Breakdown and List .....	15
40' Truss-T Boom Parts Breakdown and List.....	16
Warranty Registration.....	17-18
Sprayer Checklist .....	20

## SAFETY

**TAKE NOTE! THIS SAFETY ALERT SYMBOL FOUND THROUGHOUT THIS MANUAL IS USED TO CALL YOUR ATTENTION TO INSTRUCTIONS INVOLVING YOUR PERSONAL SAFETY AND SAFETY OF OTHERS. FAILURE TO FOLLOW THESE INSTRUCTIONS CAN RESULT IN INJURY OR DEATH.**



**THIS SYMBOL MEANS**

**ATTENTION**

**BECOME ALERT**

**YOUR SAFETY IS INVOLVED!**

### **SIGNAL WORDS**

Note: use of the following signal words **DANGER**, **WARNING**, and **CAUTION** with safety messages. Appropriate signal word for each has been selected using following guidelines:

#### **DANGER:**

Indicates an imminently hazardous situation that, if not avoided, will result in death or serious injury. This signal word is to be limited to most extreme situations typically for machine components which, for functional purposes, cannot be guarded.

#### **WARNING:**

Indicates a potentially hazardous situation that, if not avoided, could result in death or serious injury, and includes hazards that are exposed when guards are removed. It may also be used to alert against unsafe practices.

#### **CAUTION:**

Indicates a potentially hazardous situation that, if not avoided, may result in minor or moderate injury. It may also be used to alert against unsafe

If you have questions not answered in this manual, require additional copies, or if your manual is damaged, please contact your dealer or Demco, P.O. Box 189, 4010 320th Street, Boyden, IA 51234  
ph: (712) 725-2311 Toll Free: 1-800-543-3626 Fax: (712) 725-2380 <http://www.demco-products.com>



## SAFETY...YOU CAN LIVE WITH IT



### EQUIPMENT SAFETY GUIDELINES

Every year many accidents occur which could be avoided by a few seconds of thought and more careful approach to handling equipment. You, the operator, can avoid accidents by observing precautions in this section. To avoid personal injury, study precautions and insist those working with you, or you yourself, follow them.

In order to provide a better view, certain illustrations in this manual may show an assembly with a safety shield removed. However, sprayer should never be operated in this condition. Keep all shields in place. If shield removal becomes necessary for repairs, replace shield prior to use.

Replace any caution, warning, danger or instruction safety decal that is not readable or is missing. Location of such decals is indicated in this booklet.

Do not attempt to operate this sprayer under the influence of alcohol or drugs.

Review safety instructions with all users.

Operator should be a responsible adult. **DO NOT ALLOW PERSONS TO OPERATE OR ASSEMBLE THIS SPRAYER UNTIL THEY HAVE DEVELOPED A THOROUGH UNDERSTANDING OF SAFETY PRECAUTIONS AND HOW IT WORKS.**

To prevent injury or death, use a tractor equipped with a roll over protective system (ROPS). Do not paint over, remove, or deface any safety signs or warning decals on your sprayer. Observe all safety signs and practice instructions on them.

Never exceed limits of sprayer. If its ability to do a job, or to do so safely is in question **DON'T TRY IT.**



### LIGHTING AND MARKING

It is the responsibility of operator to know lighting and marking requirements of local highway authorities and to install and maintain equipment to provide compliance with regulations. Add extra lights when transporting at night or during periods of limited visibility.

Lighting kits are available from your dealer or manufacturer.



## **SAFETY SIGN CARE**

- Keep safety signs clean and legible at all times.
- Replace safety signs that are missing or have become illegible.
- Replacement parts that displayed a safety sign should also display current sign.
- Safety signs are available from your distributor, dealer parts department, or manufacturer.

### **How to install safety signs:**

- Be sure installation area is clean and dry.
- Decide on exact position before you remove backing paper.
- Remove smallest portion of split backing paper.
- Align decal over specified area and carefully press small portion with exposed sticky backing in place.
- Slowly peel back remaining paper and carefully smooth remaining portion of decal into place.
- Small air pockets can be pierced with a pin and smoothed out using piece of decal backing paper.



## **TIRE SAFETY**

- Failure to follow proper procedures when mounting tire on rim can produce an explosion resulting in serious injury or death.
- Do not attempt to mount tire unless you have proper equipment and experience.
- Inflating or servicing tires can be dangerous. Whenever possible, trained personnel should be called to service or mount tires.
- Always order and install tires and wheels with appropriate type and load capacity to meet or exceed anticipated weight to be placed on sprayer.



## **REMEMBER**

Your best assurance against accidents is a careful and responsible operator. If there is any portion of this manual or function you do not understand, contact your local authorized dealer or manufacturer.



## **BEFORE OPERATION:**

- Carefully study and understand this manual.
- Do not wear loose-fitting clothing which may catch in moving parts.
- Always wear protective clothing and substantial shoes.
- It is recommended that suitable hearing and eye protection be worn.
- Operator may come in contact with certain materials which may require specific safety equipment relative to handling of such materials. (Examples: extremely dusty, molds, fungus, bulk fertilizers, etc.)

- Keep wheel and lug nuts tightened to specified torque.
- Assure that agricultural implement tires are inflated evenly.
- Give sprayer a visual inspection for any loose bolts, worn parts, or cracked welds, and make necessary repairs. Follow maintenance safety instructions included in this manual.
- Be sure there are no tools lying on or in equipment
- Do not use the sprayer until you are sure that area is clear, especially around children and animals.
- Don't hurry learning process or take sprayer for granted. Ease into it and become familiar with your new equipment.
- Practice operation of your sprayer and its attachments. Completely familiarize yourself and other operators with its operation before using.
- Use a tractor equipped with Roll Over Protection System (ROPS) and fasten your seatbelt prior to starting engine.
- Manufacturer does not recommend usage of tractor with ROPS removed.
- Move tractor wheels to widest recommended settings to increase stability.
- Do not allow anyone to stand between tongue or hitch and towing unit when backing up to equipment.



## **DURING OPERATION**

- Beware of bystanders, **PARTICULARLY CHILDREN!** Always look around to make sure it is safe to start engine of towing unit or move sprayer. This is particularly important with higher noise levels and quiet cabs, as you may not hear people shouting.
- **NO PASSENGERS ALLOWED-** Do not carry passengers anywhere on or in the tractor or sprayer.
- Keep hands and clothing clear of moving parts.
- Do not clean, lubricate, or adjust your sprayer while it is moving.
- When halting operation, even periodically, set tractor or towing unit brakes, disengage PTO, shut off engine, and **remove ignition key**.
- Be especially observant of operating area and terrain- watch for holes, rocks, or other hidden hazards. Always inspect area prior to operation.
  - DO NOT operate near edge of drop-offs or banks.
  - DO NOT operate on steep slopes as overturn may result.
  - Operate up and down (not across) intermediate slopes. Avoid sudden starts and stops.

- Pick the most level possible route when transporting across fields. Avoid edges of ditches, gullies, and steep hillsides.
- Be extra careful when working on inclines.
- Periodically clear equipment of brush, twigs, or other materials to prevent buildup of dry combustible materials.
- Maneuver tractor or towing unit at safe speeds.
- Avoid overhead wires or other obstacles. Contact with overhead lines could cause serious injury or death.
- Avoid loose gravel, rocks, and holes; they can be dangerous for equipment operation or movement.
- Allow for sprayer length when making turns.
- Do not walk or work under raised components or attachments unless securely positioned and blocked.
- Keep all bystanders, pets, and livestock clear of work area.
- Operate towing unit from operators seat only.
- Never stand alongside of unit with engine running or attempt to start engine and/or operate machine while standing alongside of unit.
- Never leave running equipment attachments unattended.
- As a precaution, always recheck hardware on equipment following every 100 hours of operation. Correct all problems. Follow maintenance safety procedures.



## **FOLLOWING OPERATION**

- Following operation, or when unhitching, stop tractor or towing unit, set brakes, disengage PTO and all power drives, shut off engine and **remove ignition key**.
- Store sprayer in an area away from human activity.
- Do not park sprayer where it will be exposed to livestock for long periods of time. Damage and livestock injury could result.
- Do not permit children to play on or around the stored sprayer.
- Make sure all parked machines are on a hard, level surface and engage all safety devices.
- Wheel chocks may be needed to prevent unit from rolling.



## **HIGHWAY AND TRANSPORT OPERATIONS**

- **SAFETY CHAINS:** If equipment is going to be transported on a public highway, always follow state and local regulations regarding safety chains and auxiliary lighting. Be sure to check with local law enforcement agencies for your own particular regulations. If required safety chains should be obtained and installed. Only safety chains (not elastic or nylon/plastic tow straps) should be used to retain connection between towing and towed machines in event of separation of primary attaching system. Use a high strength, appropriately sized hitch pin with a mechanical retainer and attach safety chains. Criss cross chains under tongue and secure to draw bar cage, mounting loops, or bumper frame.
- Adopt safe driving practices:
  - Keep brake pedals latched together at all times. **NEVER USE INDEPENDENT BRAKING WITH SPRAYER IN TOW. LOSS OF CONTROL OR UPSET MAY RESULT.**
  - Always drive at a safe speed relative to local conditions and ensure that your speed is low enough for an emergency stop. Keep speed to a minimum.
  - Reduce speed prior to turns to avoid risk of overturning.
  - Always keep tractor or towing unit in gear to provide engine braking when going downhill. Do not coast.
  - Do not drink and drive!
- Comply with state and local laws governing highway safety and movement of farm machinery on public roads.
- Use approved accessory lighting flags and necessary warning devices to protect operators of other vehicles on highway during transport. Various safety lights and devices are available from your dealer.
- Use of flashing amber lights is acceptable in most localities. However, some localities prohibit their use. Local laws should be checked for all highway lighting and marking requirements.
- When driving tractor and sprayer under 20 mph (40 kph) day or night, use flashing amber warning lights and a slow moving vehicle (SMV) identification emblem.
- Plan your route to avoid heavy traffic.
- Be a safe and courteous driver. Always yield to oncoming traffic in all situations, including narrow bridges, intersections, etc.
- Be observant of bridge load ratings. Do not cross bridges rated lower than gross weight of unit you are operating.

- Watch for obstructions overhead and side to side while transporting.
- Always operate equipment in a position to provide maximum visibility at all times. Make allowances for increased length and weight of sprayer when making turns, or stopping.



## **PERFORMING MAINTENANCE**

- Good maintenance is your responsibility. Poor maintenance is an invitation to trouble.
- Make sure there is plenty of ventilation. Never operate engine of towing vehicle in a closed building. Exhaust fumes may cause asphyxiation.
- Before working on this machine, stop towing vehicle, set brakes, disengage PTO and all power drives, shut off engine and **remove ignition key**.
- Be certain all moving parts and attachments have come to a complete stop before attempting to perform maintenance.
- Always use a safety support and block wheels. Never use a jack to support machine.
- Always use proper tools or equipment for job at hand.
- Use extreme caution when making adjustments.
- Follow torque chart in this manual when tightening bolts and nuts.
- Never use your hands to locate a hydraulic leak on attachments. Use a small piece of cardboard or wood. Hydraulic fluid escaping under pressure can penetrate skin.
- Openings in skin and minor cuts are susceptible to infection from hydraulic fluid.  
**Without immediate medical treatment, serious infection and reactions can occur.**
- When disconnecting hydraulic lines, shut off hydraulic supply and relieve all hydraulic pressure.
- Replace **all shields** and **guards** after servicing and before moving.
- After servicing, be sure all tools, parts and service equipment are removed.
- Do not allow grease or oil to build up on any steps or platform.
- When replacing bolts refer to owners manual.
- Refer to bolt torque chart for head identification marking.
- Where replacement parts are necessary for periodic maintenance and servicing, genuine factory replacement parts must be used to restore your equipment to original specifications. Manufacturer will not claim responsibility for use of unapproved parts or accessories and other damages as a result of their use.
- If equipment has been altered in any way from original design, manufacturer does not accept any liability for injury or warranty.
- A fire extinguisher and first aid kit should be kept readily accessible while performing maintenance on this equipment

## BOLT TORQUE

### TORQUE DATA FOR STANDARD NUTS, BOLTS, AND CAPSCREWS.

Tighten all bolts to torques specified in chart unless otherwise noted. Check tightness of bolts periodically, using bolt chart as guide. Replace hardware with same grade bolt.

NOTE: Unless otherwise specified, high-strength Grade 5 hex bolts are used throughout assembly of equipment.



#### Torque Specifications

**Bolt Torque for Standard bolts \***

"A"	GRADE 2		GRADE 5		GRADE 8	
	lb-ft	(N.m)	lb-ft	(N.m)	lb-ft	(N.m)
1/4"	6	(8)	9	(12)	12	(16)
5/16"	10	(13)	18	(25)	25	(35)
3/8"	20	(27)	30	(40)	45	(60)
7/16"	30	(40)	50	(70)	80	(110)
1/2"	45	(60)	75	(100)	115	(155)
9/16"	70	(95)	115	(155)	165	(220)
5/8"	95	(130)	150	(200)	225	(300)
3/4"	165	(225)	290	(390)	400	(540)
7/8"	170	(230)	420	(570)	650	(880)
1"	225	(300)	630	(850)	970	(1310)

**Bolt Torque for Metric bolts \***

"A"	CLASS 8.8		CLASS 9.8		CLASS 10.9	
	lb-ft	(N.m)	lb-ft	(N.m)	lb-ft	(N.m)
6	9	(13)	10	(14)	13	(17)
7	15	(21)	18	(24)	21	(29)
8	23	(31)	25	(34)	31	(42)
10	45	(61)	50	(68)	61	(83)
12	78	(106)	88	(118)	106	(144)
14	125	(169)	140	(189)	170	(230)
16	194	(263)	216	(293)	263	(357)
18	268	(363)	--	--	364	(493)
20	378	(513)	--	--	515	(689)
22	516	(699)	--	--	702	(952)
24	654	(886)	--	--	890	(1206)

Torque figures indicated are valid for non-greased or non-oiled threads and heads unless otherwise specified. Therefore, do not grease or oil bolts or capscrews unless otherwise specified in this manual. When using locking elements, increase torque values by 5%.

\* GRADE or CLASS value for bolts and capscrews are identified by their head markings.

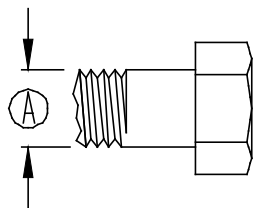

GRADE-2

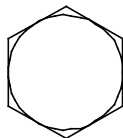

GRADE-5

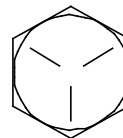

GRADE-8

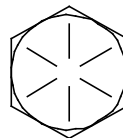

CLASS 8.8



CLASS 9.8



CLASS 10.9



## SPRAYER TIP ASSEMBLY INSTALLATION

**DEMCO Booms** are sold in 21, 28, 30 and 40' foot models. Tip placement will depend on the tip being used. When broadcast spraying with Flat Spray Tips, 20 inch tip spacing must be used and when spraying with Floodjet Tips, 40 inch spacing must be used.

### 1. Marking Location of Boom Clamps

Mark the clamp locations by starting in the center of the main boom frame. From this mark locate 20 inch spaces to the ends of both boom wings.

### 2. Fastening Boom Clamps

On the left wing and center section fasten the boom clamps on the boom so the sprayer tip will be on the back side of the boom, on the right wing place them on the front of the boom. This is to prevent the tips from being broken when the boom wings are folded into the transport position.

### 3. Sprayer Tip Assembly

**Flat Sprayer Tips** - Insert a sprayer tip assembly and tip into each of the sprayer boom clamps.

**Floodjet Tips** - Insert a sprayer tip assembly less tip into each sprayer boom clamp. Place a floodjet tip into every other boom clamp assembly and a blank into all remaining assemblies.

### 4. Installing Hoses and Insert Tees

Install the 1/2" hoses on the booms between each boom clamp assembly and fasten with the hose clamps. Install an insert tee in the middle of each one of the three boom sections as shown in the figure below.

**NOTE: For ease of putting hoses on fitting barbs, dip ends in a soap solution.**

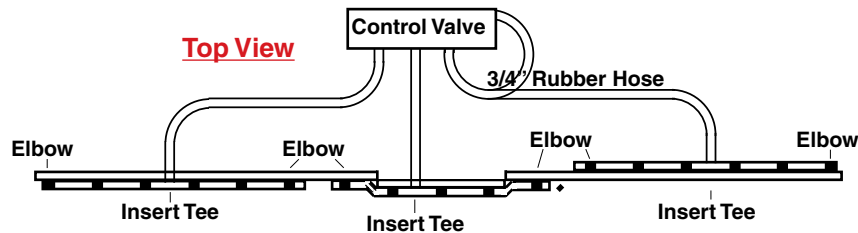

## SPRAYER CALIBRATION PROCEDURES

**NOTE:** To avoid wind drift, use lower pressure and higher spray volume.

### Guidelines For Sprayer Calibration

Before calibrating your sprayer, first determine whether each nozzle is delivering at a uniform rate. Place quart jars under all nozzles and watch as they fill up. The level should rise uniformly and take the same time (within 10%) for all nozzles to fill the jars. Replace any nozzle showing a discharge rate different from the others.

### Calibrating the Sprayer

1. Mark off 660 feet (1/8 mile).
2. Fill the tank with water.
3. Set the sprayer to your desired operating pressure.
4. Turn the sprayer on and drive at the constant speed you will be spraying. Calibration on a road or unplowed field will give different results than on soft cultivated ground. **Note** tachometer reading so same speed can be maintained later.
5. Measure the amount of water it takes to refill the tank completely.
6. Calculate the amount applied:

$$\frac{\text{Number of gallons used} \times 66 \text{ (factor)}}{\text{Spray Swath in Feet}} \quad \text{per acre} \quad \text{Gallons applied}$$

**Example:** If 10 gallons are used in 660 feet and the spray swath is 28 feet, spraying rate is 23.57 gallons per acre.

$$\frac{10 \times 66}{28} = \frac{660}{28} \quad \text{or } 23.57 \text{ gallons per acre}$$

7. To calculate the amount of chemical to put in the tank:

$$\frac{\text{Sprayer Tank Size}}{\text{Desired GPA}} = \text{Acres covered} \quad \text{then;}$$

$$\text{Recom. amount of chemical per acre} \times \text{Acres covered} = \text{Amt. of chemical per tankful}$$

**Example:** If a 300 gallon tank is used and 23.57 gallons per acre are applied, one tank will cover 12.72 acres. If three pounds of chemical are required per acre, then 38.1 pounds of chemical are required per tankful.

$$\frac{300}{23.57} = 12.72 \text{ acres covered} \quad \text{then;}$$

**To determine GPA at other nominal speeds.**

Sprayer Speed	Multiply by Speed Factor
4 mph	1.25
5 mph	1.00
6 mph	.83
7.5 mph	.67
10 mph	.50

## FLAT SPRAY NOZZLE FOR BROADCAST SPRAYING

Nozzle No.	Liquid Pressure In PSI.	Nozzle Capacity In GPM	Gallons Per Acre Based on 20" Nozzle Spacing			
			4 MPH	5 MPH	7.5 MPH	10 MPH
8001 or XR8001VS	20	.07	5.3	4.3	2.8	2.2
	25	.08	5.9	4.7	3.1	2.4
	30	.09	6.4	5.1	3.4	2.6
	40	.10	7.4	6.0	4.0	3.0
80015 or XR80015VS	20	.11	7.8	6.3	4.3	3.2
	25	.12	8.8	7.1	4.7	3.6
	30	.13	9.7	7.7	5.2	3.9
	40	.15	11.1	8.9	6.0	4.5
8002 or XR8002VS	20	.14	10.5	8.4	5.6	4.2
	25	.16	11.8	9.4	6.3	4.7
	30	.17	12.9	10.3	6.9	5.2
	40	.20	14.8	11.8	7.9	5.9
8003 or XR8003VS	20	.21	15.7	12.6	8.4	6.3
	25	.24	17.6	14.1	9.4	7.1
	30	.26	19.0	15.4	10.3	7.7
	40	.30	22.0	17.8	11.8	8.9
8004 or XR8004VS	20	.28	21.0	16.8	11.2	8.4
	25	.32	24.0	18.7	12.5	9.4
	30	.35	26.0	21.0	13.7	10.3
	40	.40	30.0	24.0	15.8	11.9
8005 or XR8005VS	20	.35	26.0	21.0	14.0	10.5
	25	.40	29.0	23.0	15.7	11.7
	30	.43	32.0	26.0	17.2	12.9
	40	.50	37.0	30.0	19.8	14.9
8006 or XR8006VS	20	.42	31.0	25.0	16.9	12.6
	25	.47	35.0	28.0	18.7	14.1
	30	.52	39.0	31.0	21.0	15.5
	40	.60	45.0	36.0	24.0	17.8
8008 or XR8008VS	20	.56	42.0	34.0	22.0	17.0
	25	.63	47.0	37.0	25.0	19.0
	30	.69	52.0	41.0	27.0	21.0
	40	.80	59.0	48.0	32.0	24.0
8010 or XR8010VS	20	.70	53.0	42.0	28.0	21.0
	25	.78	59.0	47.0	31.0	24.0
	30	.86	64.0	51.0	34.0	26.0
	40	1.00	74.0	59.0	40.0	30.0

Tabulations for all the following charts are based on spraying water. For different weight fertilizer solutions, obtain the appropriate conversion factor from the table below.

Weight of Solution	Specific Gravity	Conversion Factors
7.0 lbs. per gallon	.84	1.09
8.0 lbs. per gallon	.96	1.02
<b>8.34 lbs. per gallon-WATER</b>	<b>1.00</b>	<b>1.00</b>
9.0 lbs. per gallon	1.08	.96
10.0 lbs. per gallon	1.20	.91
11.0 lbs. per gallon	1.32	.87
12.0 lbs. per gallon	1.44	.83
14.0 lbs. per gallon	1.68	.77
16.0 lbs. per gallon	1.92	.72
18.0 lbs. per gallon	2.16	.68
20.0 lbs. per gallon	2.40	.65

Imperial Gallon = 1.20 U.S.A. Gallons

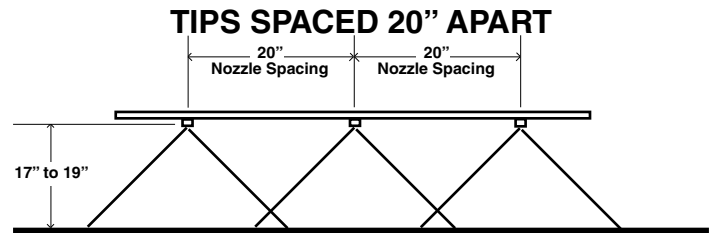

## FLOODJET TIPS FOR BROADCAST SPRAYING

Nozzle No.	Orifice Dia.	Liquid Pressure In PSI.	Capacity In GPM.	Gallons Per Acre				
				4 MPH	5 MPH	6 MPH	8 MPH	10 MPH
TKVS1	.033"	10	.10	3.7	3.0	2.5	1.9	1.5
		20	.14	5.3	4.3	3.5	2.6	2.1
		30	.17	6.4	5.1	4.2	3.2	2.6
		40	.20	7.4	6.0	4.9	3.7	3.0
TKVS1.5	.041"	10	.15	5.6	4.5	3.7	2.7	2.0
		20	.21	7.8	6.3	5.2	3.9	2.9
		30	.26	9.7	7.7	6.5	4.8	3.5
		40	.30	11.1	8.9	7.4	5.6	4.1
TKVS2	.046"	10	.20	7.4	6.0	4.9	3.7	3.0
		20	.28	10.5	8.4	6.9	5.2	4.2
		30	.35	12.9	10.3	8.7	6.5	5.2
		40	.40	14.8	11.8	9.9	7.5	5.9
TKVS2.5	.052"	10	.25	9.3	7.4	6.1	4.6	3.7
		20	.35	12.9	10.3	8.7	6.5	5.2
		30	.43	15.9	12.8	10.6	8.0	6.4
		40	.50	18.6	14.9	12.4	9.3	7.4
TKVS3	.057"	10	.30	11.1	8.9	7.5	5.6	4.5
		20	.42	15.7	12.6	10.4	7.8	6.3
		30	.52	19.3	15.4	12.8	9.7	7.7
		40	.60	22.0	17.8	14.8	11.2	8.9
TKVS4	.065"	10	.40	14.9	11.9	9.9	7.5	5.9
		20	.57	21.0	16.8	13.9	10.5	8.4
		30	.69	26.0	21.0	17.1	12.8	10.3
		40	.80	30.0	24.0	19.8	14.8	11.9
TKVS5	.073"	10	.50	18.6	14.9	12.4	9.3	7.4
		20	.71	27.0	21.0	17.6	13.1	10.7
		30	.87	33.0	26.0	21.7	16.1	13.1
		40	1.00	38.0	30.0	25.2	18.6	15.1
TKVS7.5	.091	10	.75	28.0	22.0	18.7	14.0	11.1
		20	1.10	39.0	32.0	26.4	19.8	15.8
		30	1.30	49.0	39.0	31.9	24.1	19.3
		40	1.50	56.0	45.0	37.4	27.5	22.0
TKVS10	.104"	10	1.00	38.0	30.0	25.2	18.5	15.1
		20	1.40	53.0	41.7	35.2	26.4	21.0
		30	1.70	64.0	51.0	41.7	31.9	26.0
		40	2.00	75.0	60.0	49.4	37.4	30.0
TKSS15	.129"	10	1.50	56.0	45.0	37.4	27.5	22.0
		20	2.10	79.0	63.0	51.6	39.6	31.0
		30	2.60	97.0	77.0	64.8	48.3	39.0
		40	3.00	111.0	89.0	74.7	56.0	45.0
TKSS20	.148"	10	2.00	75.0	60.0	49.4	37.4	30.0
		20	2.80	104.0	83.0	69.2	52.7	42.0
		30	3.50	130.0	104.0	86.8	64.8	52.0
		40	4.00	149.0	119.0	100.0	74.7	59.0
TKSS30	.180"	10	3.00	111.0	89.0	74.7	56.0	45.0
		20	4.2	156.0	124.0	104.4	78.2	62.0
		30	5.10	189.0	151.0	126.4	95.6	76.0
		40	6.000	222.0	178.0	149.4	112.0	89.0

Floodjet tips are positioned as shown in the diagram by the chart below. When positioning the tip as shown in Figure A the tip can be operated closer to the ground, thereby reducing the chance of wind drift.

The chart below shows capacities in gallons per acre at various speeds and liquid pressures. Capacities are based on water at 70 degrees F. with nozzles spaced at 40 inches.

The rate chart is based on 40 inch row spacings. For other spacings of nozzles on the boom, multiply the tabulated GPA coverage by the conversion factors shown

Other Spacing	20	24	28	30	32	34	36	38	40	42	44
Conversion Factor	2	1.67	1.43	1.33	1.25	1.18	1.11	1.05	1.00	.95	.91

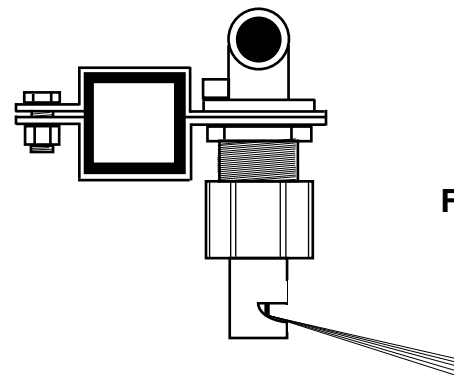
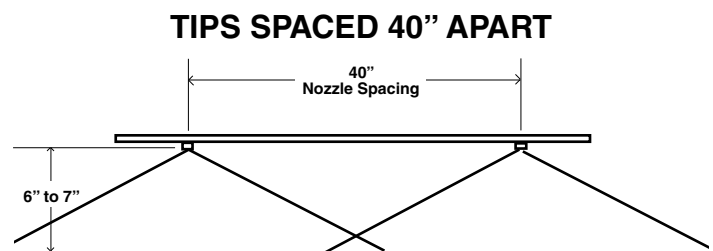
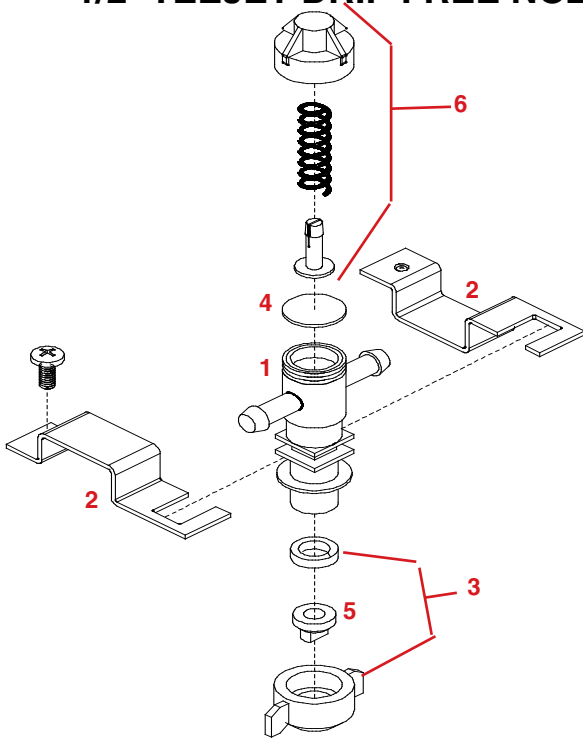

Figure A



Flat Uniform Sprayer Pattern

## 1/2" TEEJET DRIP FREE NOZZLES



### 1/2" TEEJET DRIP FREE NOZZLE PARTS LIST

REF. NO.	PART NO.	DESCRIPTION
1.	09310	1/2" Single End Nozzle Assembly(Inc'd #6)
-	09311	1/2" Single Tee Nozzle Assembly(Inc'd #6)
2.	10903	1-1/4" Square Stainless Steel Boom Clamp (Includes Bolt)
3.	07787	Flat Fan Cap (Includes EPDM Gasket)
4.	21953VI	Diaphragm (Viton)
5.	----	Tip (Specify Tip Size) (Not Included)
6.	21950 10PP	End Cap Assembly

Please order replacement parts by PART NO. and DESCRIPTION.

## CONVENTIONAL NOZZLES and BOOM CLAMPS

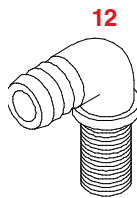
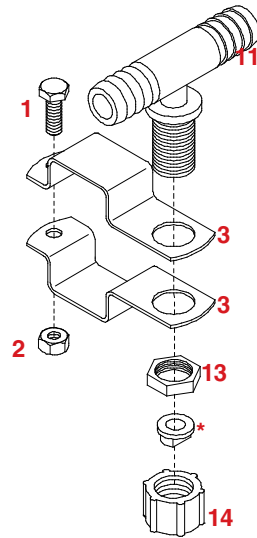

### 1-1/4" BOOM CLAMP PARTS LIST

REF. NO.	PART NO.	DESCRIPTION
-	B11 114	1-1/4" Boom Clamp Assembly
1.	00068	1/4"-20UNC x 3/4" Hex Hd. Bolt
2.	00062	1/2"-20UNC Hex Nut
3.	00337-95	1-1/4" Boom Clamp

### 1/2" NOZZLE PARTS LIST

REF. NO.	PART NO.	DESCRIPTION
11.	NTT12	1/2" Nozzle Tee
12.	NLT12	1/2" Nozzle elbow
13.	B12	Nut
*	---	Tip (specify tip size) (not included)
14.	8027	11/16" FPS Cap

Please order replacement parts by PART NO. and DESCRIPTION.

# 21', 28' AND 30' TRUSS-T BOOM PARTS BREAKDOWN

**NOTE:** Bracket #27 is only used when conventional nozzles are used.

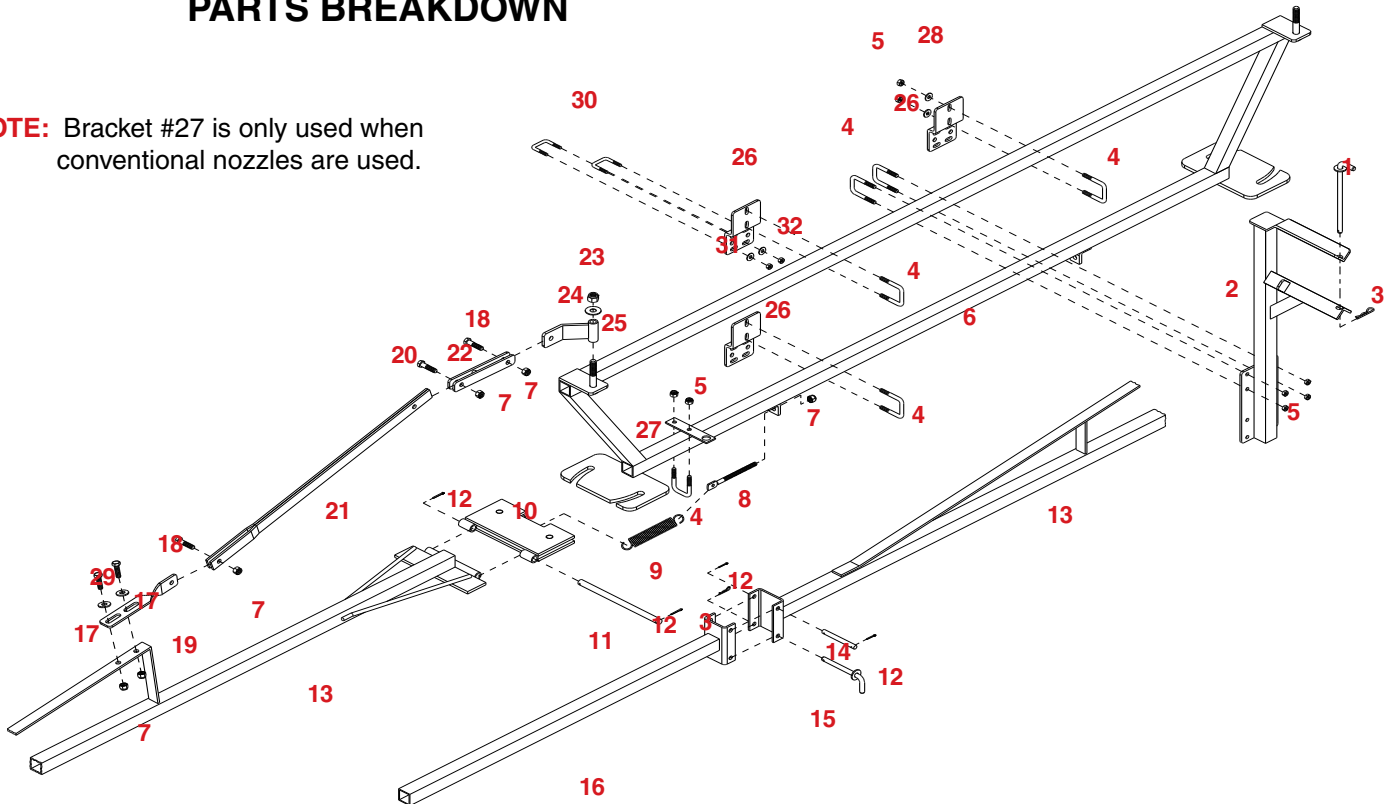

## TRUSS-T BOOM PARTS LIST

REF. NO.	PART NO.	QTY.	DESCRIPTION
1.	00183-95	1	3/8" dia. x 6-3/4" lg. Removable Pin
2.	02687-30	1	Boom Storage Bracket
3.	00182	3	1/8" Small Hair Pin
4.	00909	8	5/16"-18 UNC x 1-1/4" Square U-Bolt
5.	02802	16	5/16"-18 UNC Nylon Insert Locknut
6.	02680-30	1	Center Section (Truss-T)
7.	02592	12	3/8"-16 UNC Nylon Insert Locknut
8.	00357	2	3/8"-16 UNC x 4-1/2" Tension Bolt
9.	00180-30	2	Break-Away Spring
-	5098-30	2	21' Boom Wing with Hinge
10.	02679-30	1	Boom Wing Hinge
11.	00168	1	1/2" dia. x 8-3/4" lg. Hinge Pin
12.	00009	2	1/8" x 1" Cotter Pin
13.	02681-30	1	Boom Wing (Truss-T)
12.	00009	4	1/8" x 1" Cotter Pin
14.	00863	2	3/8" dia. x 3-1/2" lg. Hinge Pin
15.	00199-95	2	3/8" dia. x 4-1/2" lg. Removable Pin
16.	02682-30	2	Boom Wing Extension (28 ft.)
-	02751-30	2	Boom Wing Extension (30 ft.)
17.	00059	4	3/8" Flatwasher
18.	00523	4	3/8"-16 UNC x 1-1/4" Hex Head Bolt
19.	02686-30	2	Linkage Mount
20.	00914	6	3/8"-16 UNC x 1-1/2" Hex Head Bolt
21.	02683-30	2	Long Knee Action Linkage
22.	02684-30	2	Short Linkage
23.	02178	2	1/2"-13 UNC Nylon Insert Locknut
24.	00085	2	1/2" Flatwasher
25.	02685-30	2	Linkage Pivot Arm
26.	02678-95	4	Boom Mounting Plate
27.	04295-95	2	Nozzle Extension Plate
28.	00004	8	5/16" Flatwasher
29.	00907	4	3/8"-16 UNC x 1" Hex Head Bolt
30.	04822	8	1/4"-18 UNC x 1" Square U-Bolt
31.	00214	16	1/4" Flatwasher
32.	02772	16	1/4"-18 UNC Nylon Insert Locknut

## ASSEMBLED LINKAGE

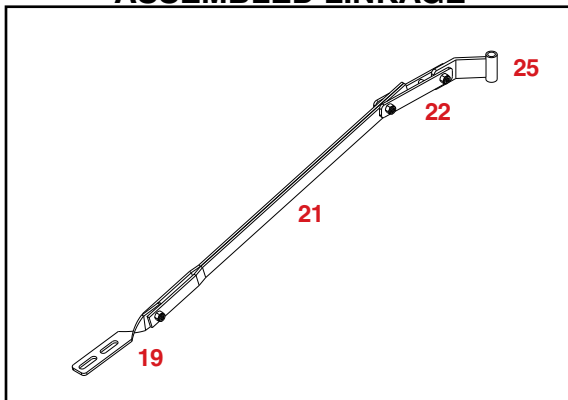

Please order replacement parts by PART NO. and DESCRIPTION.

# 40' TRUSS-T BOOM PARTS BREAKDOWN

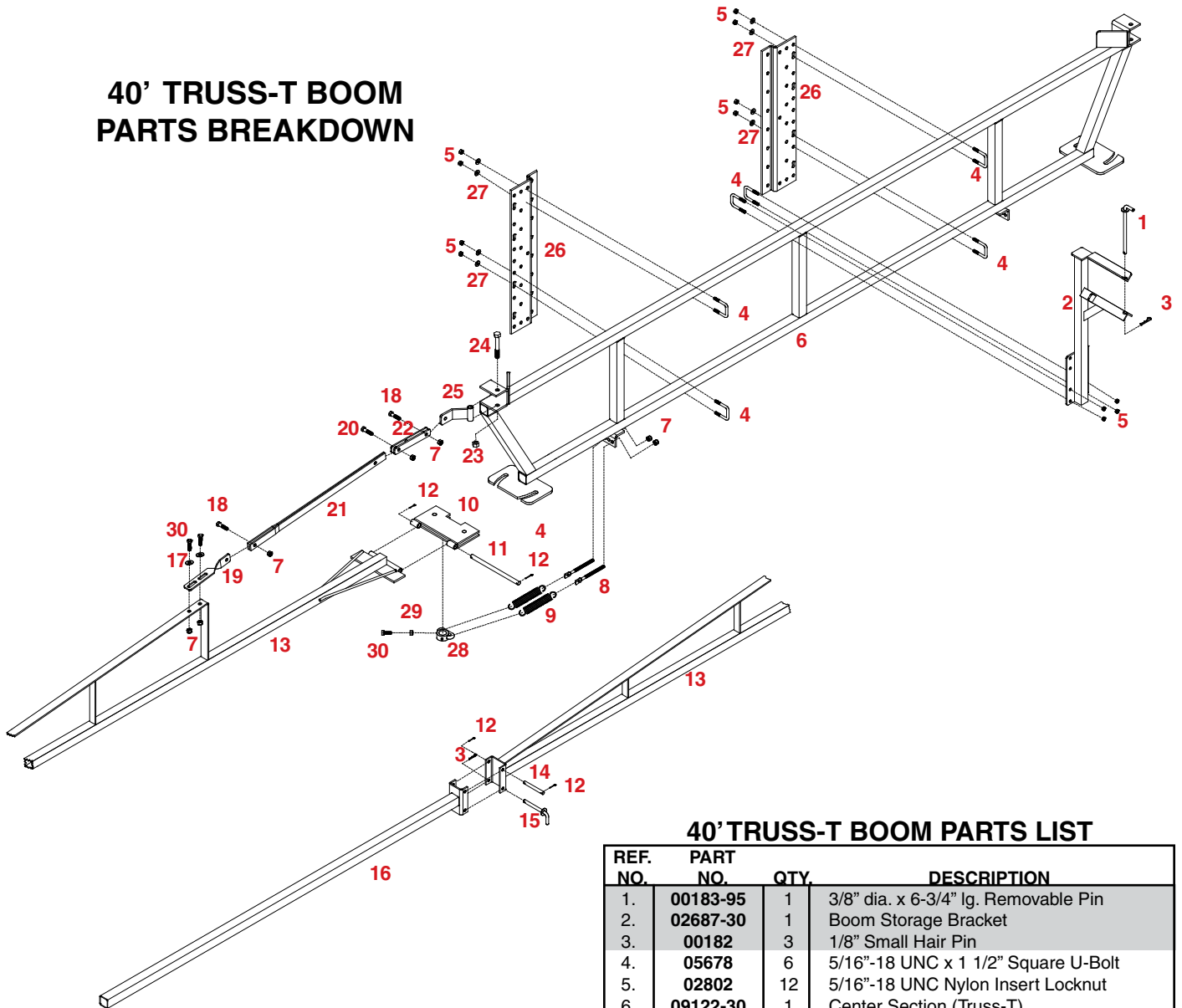

## 40' TRUSS-T BOOM PARTS LIST

REF. NO.	PART NO.	QTY.	DESCRIPTION
1.	00183-95	1	3/8" dia. x 6-3/4" lg. Removable Pin
2.	02687-30	1	Boom Storage Bracket
3.	00182	3	1/8" Small Hair Pin
4.	05678	6	5/16"-18 UNC x 1 1/2" Square U-Bolt
5.	02802	12	5/16"-18 UNC Nylon Insert Locknut
6.	09122-30	1	Center Section (Truss-T)
7.	02592	10	3/8"-16 UNC Nylon Insert Locknut
8.	00357	4	3/8"-16 UNC x 4-1/2" Tension Bolt
9.	00180-30	4	Break-Away Spring
10.	02679-30	2	Boom Wing Hinge
11.	00168	2	1/2" dia. x 8-3/4" lg. Hinge Pin
12.	00009	10	1/8" x 1" Cotter Pin
13.	09123-30	2	Boom Wing (Truss-T)
14.	00863-95	2	3/8" dia. x 3-1/2" lg. Hinge Pin
15.	00199-95	2	3/8" dia. x 4-1/2" lg. Removeable Pin
16.	09121-30	2	Boom Wing Extension
17.	00059	4	3/8" Flatwasher
18.	00523	6	3/8"-16 UNC x 1-1/4" Hex Head Bolt
19.	02686-30	2	Linkage Mount
20.	00914	4	3/8"-16 UNC x 1-1/2" Hex Head Bolt
21.	02683-30	2	Long Knee Action Linkage
22.	02684-30	2	Short Linkage
23.	02178	2	1/2"-13 UNC Nylon Insert Locknut
24.	01897	2	1/2" -13 UNC x 3 1/2" Hex Head Bolt
25.	02685-30	2	Linkage Pivot Arm
26.	03275-30	2	Boom Mounting Plate
27.	00004	8	5/16" Flatwasher
28.	00176-95	2	Spring Hook Collar
29.	00061	2	3/8" - 16 UNC Hex Nut
30.	00907	6	3/8" -16 UNC x 1" Hex Head Bolt

Please order replacement parts by PART NO. and DESCRIPTION.



# Warranty Registration

4010 320th Street • Box 189 • Boyden, Iowa 51234  
Toll Free 800-54DEMCO (800-543-3626) • FAX 800-845-6420  
www.demco-products.com

Ag	<input type="radio"/>
RV	<input type="radio"/>
Rental	<input type="radio"/>
Brakes	<input type="radio"/>
Marine	<input type="radio"/>

	Very Satisfied	Satisfied	Dissatisfied	Very Dissatisfied
How satisfied are you with our product?	<input type="radio"/>	<input type="radio"/>	<input type="radio"/>	<input type="radio"/>
How satisfied are you with the dealership/distributor sales staff? Dealer/Distributor Name _____ City _____ State _____	<input type="radio"/>	<input type="radio"/>	<input type="radio"/>	<input type="radio"/>
How satisfied are you with the company sales staff?	<input type="radio"/>	<input type="radio"/>	<input type="radio"/>	<input type="radio"/>
How satisfied are you with the delivery?	<input type="radio"/>	<input type="radio"/>	<input type="radio"/>	<input type="radio"/>
Did you have any contact with a Demco Representative? If <b>YES</b> , how satisfied were you?	YES <input type="radio"/>	NO <input type="radio"/>	<input type="radio"/>	<input type="radio"/>
I would recommend this product to my family and friends.	YES	NO		
Would you purchase again from DEMCO?	YES	NO		
Since taking delivery, have you been contacted by the dealer?	YES	NO		
Did you have any problems with this DEMCO product? If <b>YES</b> , are you satisfied with the company's resolution of your problem?	YES <input type="radio"/>	NO <input type="radio"/>	<input type="radio"/>	<input type="radio"/>

Please list the specific source of information prompting this purchase.  
\_\_\_\_\_  
\_\_\_\_\_

After purchasing this product, do you see any needed product improvement? \_\_\_\_\_ If yes, what improvement? \_\_\_\_\_  
\_\_\_\_\_

What other products would you like to see DEMCO offer? \_\_\_\_\_  
\_\_\_\_\_

Comments \_\_\_\_\_  
\_\_\_\_\_

Owner's Name: \_\_\_\_\_ Mailing Address: \_\_\_\_\_  
City: \_\_\_\_\_ State: \_\_\_\_\_ Zip Code: \_\_\_\_\_

Model#: \_\_\_\_\_  
Serial #: \_\_\_\_\_  
Purchase Date: \_\_\_\_\_

Owner's Signature: \_\_\_\_\_

Please return to DEMCO By FAX or tri-folding this form to the backside, it is pre-addressed.

Postage

*Demco  
4010 320th Street, Box 189  
Boyden, Iowa 51234*

# NOTES

# SPRAYER CHECKLIST:

Downtime caused by field breakdowns is costly and time consuming. Many breakdowns can be eliminated by periodic equipment maintenance. By spending time reviewing this checklist before seasonal spraying application time and following proper after-season care, you can save time and money later.



## **WARNING: To Prevent Serious Injury Or Death**

- Keep hands, feet, and loose clothing away from rotating parts.
- Wear protective clothing recommended by your chemical and fertilizer manufacturer when working with chemicals.

### Check Before Going To The Field :

#### 1. NOZZLES

Check tip for excessive wear by checking for grooves in or near tip opening. Check nozzle spacing by starting at center and working outwards. Check boom for proper height.

#### 2. HOSES

Check all hoses for worn or soft spots. Be sure all hose clamps are tightened and hoses are not kinked or pinched. Check for leakage in any lines.

#### 3. TANK

Remove and clean agitator orifices. Check orifices for excessive wear by checking for grooves in or near orifice opening. Inspect fitting and grommets to insure they are in good condition.

#### 4. CONTROLS

Check for leakage, plugging, or wear on all valves, fittings, etc. Clean off any build up of foreign material.

#### 5. PUMP

Check to be sure pump turns freely.

#### 6. FRAME

Be sure all bolts are tightened.

#### 7. REPLACEMENT PARTS

Replace all worn or damaged parts.

### After Season Care:

**NOTE: It is important to wear proper safety equipment when cleaning the sprayer. See your chemical or fertilizer package for this information.**

1. After spraying chemicals, run water mixed with cleaners through tank, pump and all hose hookups. If wettable powder dries out in the system, it is very difficult to put back into suspension and can cause malfunction, damage or injury.
2. When cleaned, tank should have all openings closed or covered to keep dirt from entering.
3. Pump should be flushed with soluble oil and pump ports plugged to keep out moisture and air.
4. Disassemble tips and rinse with water or cleaning solution. (Appropriate for chemical sprayed).
5. Clean tip opening with a wooden toothpick. Never use wire or hard object that could distort opening.
6. Dispose of all unused chemicals or solutions in a proper and ecologically sound manner.
7. Water rinse and dry tips before storing.
8. To prevent damage due to freezing temperatures, be sure to drain all strainer bowls. Furthermore, run RV Anti Freeze through the entire plumbing system to protect valves and other components.

**NOTE: Demco does not and will not make any recommendations concerning application of various chemicals or solutions. These recommendations relate to either amount or procedure of materials applied. If you have any questions regarding application of certain chemicals or solutions, contact your chemical supplier and follow chemical manufacturer recommendations.**



P.O. BOX 189

4010 320th St., BOYDEN, IA. 51234

PH: (712) 725-2311

FAX: (712) 725-2380

TOLL FREE: 1-800-54DEMCO (1-800-543-3626)

www.demco-products.com